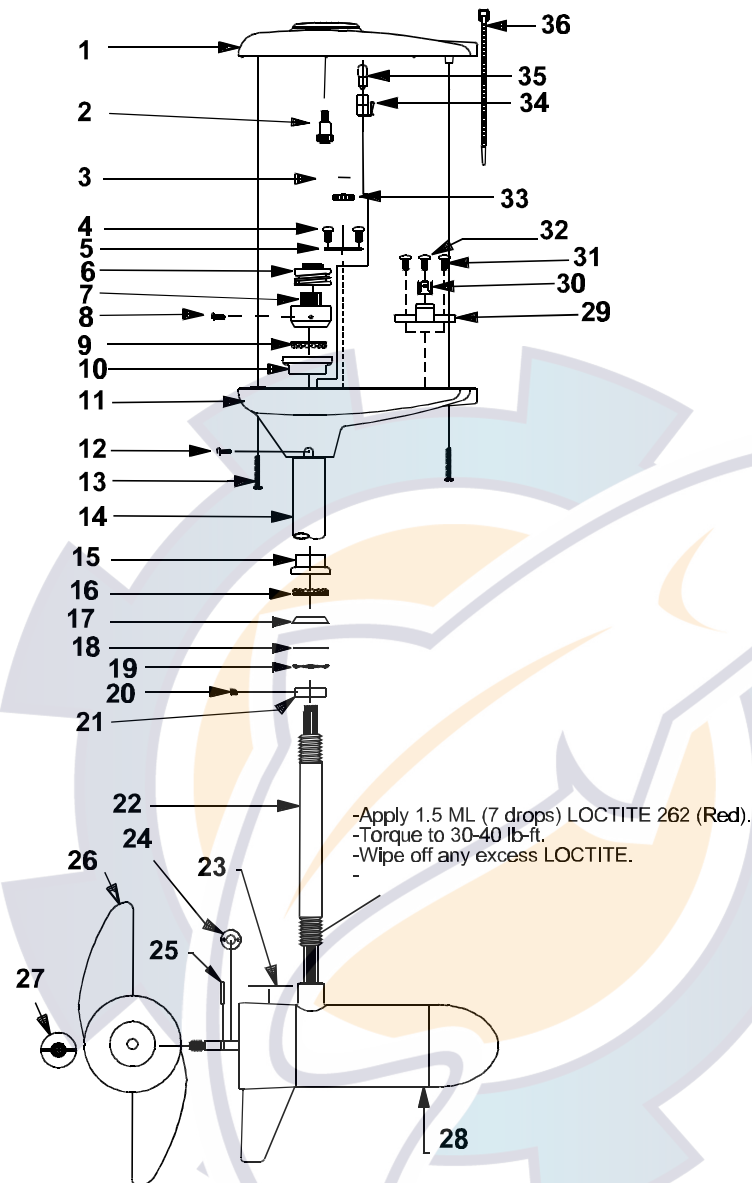

MotorGuide REPAIR PARTS

Model:
TE761

SPECIFICATIONS:

Year of Intro	1998
Thrust	61LBS
Volts	12/24VDC
Amp Draw	0 to 34 amps
Mount	20 Tour Bow
Speeds	10

QUICK REFERENCE PARTS GUIDE:

Rotary Switch	HF150-02
Toggle Switch	PM3153-02
Seal Kit	6220

PARTS ORDERING & TECH ASSISTANCE
 MotorGuide Consumer Relations
 Phone 918-831-6989
 Fax 800-982-8093

Returned Goods must be accompanied with a Returned Goods Authorization. Contact MotorGuide Consumer Relations to obtain RGA.

KEY	DESCRIPTION	PART #	KEY	DESCRIPTION	PART #
1	TOP HOUSING COVER ASY	AF053-16	26	2 BLADE PROP	AF124-07
2	INDICATOR GEAR	AF069-02	27	PROP NUT	AR099-01
3	E RING	AK046-01	28	LOWER UNIT	BF397-03
4	SCREW SS	BK136-02	29	TERMINAL BLOCK	FM029-02
5	BRACKET ASY	AF3155-01	30	TERMINAL (4 PRONG)	FT160-03
6	CABLE DRUM	FM067-01	31	SCREW SS	BK136-02
7	DRUM COUPLING	FM064-01	32	SCREW	FM133-03
8	SCREW 0133-20	FM133-01	33	IDLER GEAR	AF069-03
9	BEARING	FM005-01	34	LAMP HOLDER ASY	AF394-01
10	RETAINER/BEARING CUP	FM007-01	35	36V LAMP	AF093-01
11	TOP HOUSING BASE	AF004-11	36	CABLE TIE	AF030-01
12	SET SCREW	FM142-01			
13	SCREW #10X24X.75	AF141-02			
14	OUTER TUBE	AF165-06			
15	RETAINER/BEARING CUP	FM007-01			
16	BEARING	FM005-01			
17	BEARING RACE	AF006-03			
18	O RING	AF063-01			
19	WAVE SPRING WASHER	AF171-01			
20	CONE SET SCREW	AF143-01			
21	BEARING COLLAR	XF006-01			
22	COLUMN 42"	FM049-05			
	COLUMN 50"	FM049-08			
23	DECAL	AF060-05			
24	MONOFILAMENT WASHER	AR175-01			
25	PROP PIN	BR102-01			

PARTS NOT ILLUSTRATED
 TOP HOUSING DECAL BF056-10

LOWER UNIT BREAKDOWN

Model:
TE761

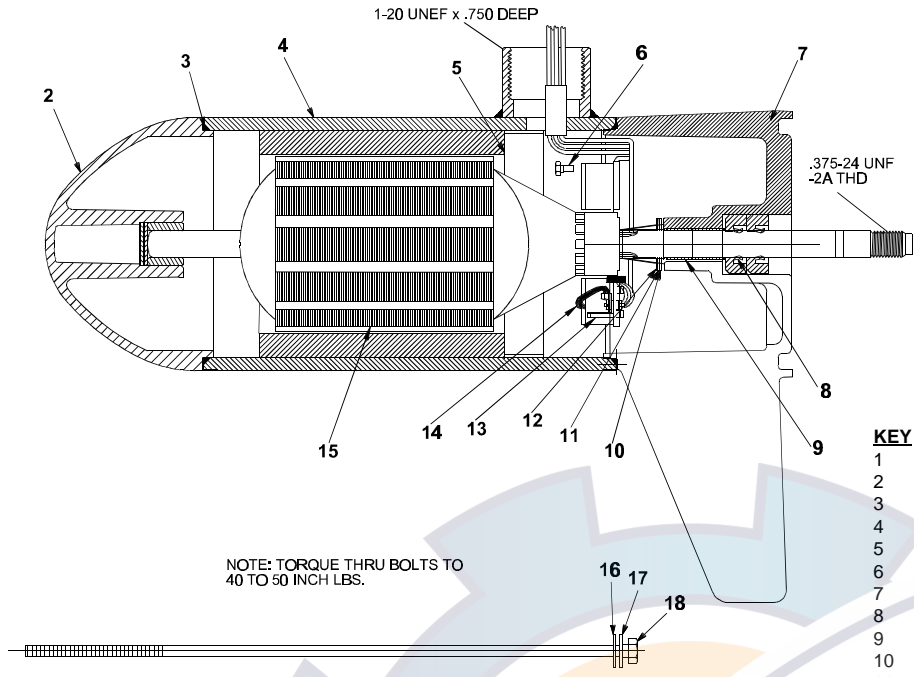

KEY	QTY	DESCRIPTION	PART NO.
1	X	MOTOR	BF397-03
2	1	NOSE CAP	JF3212-01
3	2	O RING SEAL	MR217-01
4	1	HOUSING ASY	JF3210-01
5	1	RETAINER	JF233-01
6	2	BRUSH CARD SCREW	MR228-01
7	1	COMM CAP	BF3205-02
8	2	SHAFT SEAL	MR223-01
9	1	BEARING	MR206-01
10	1	NYLATRON WASHER	MR226-01
11	1	WASHER	MR227-01
12	1	E RING	MR219-02
13	2	BRUSH SPRINGS	MR214-02
14	1	BRUSH ASY LESS SPRING	BF3201-02
15	1	ARMATURE	JF3207-01
16	4	STATIC SEAL	MR222-01
17	4	THRU BOLT WASHER	MR216-01
18	2	THRU BOLT	MR218-02

WIRING

12/24 WIRING DIAGRAM

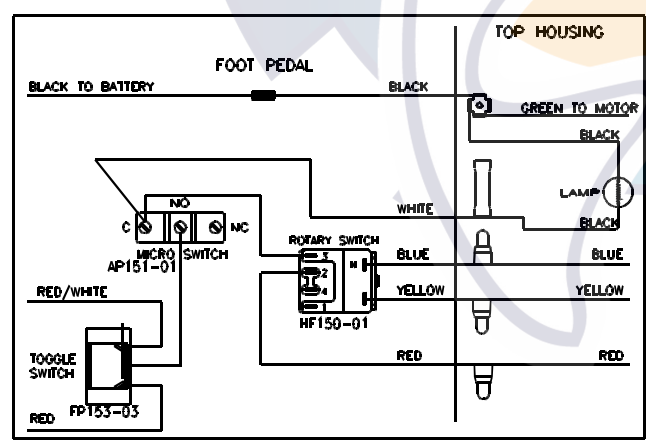

GEAR ADJUSTMENT
Loosely install two bracket mounting screws. Adjust bracket for best tooth engagement. Tighten both mounting screws to 18-20 inch lbs.

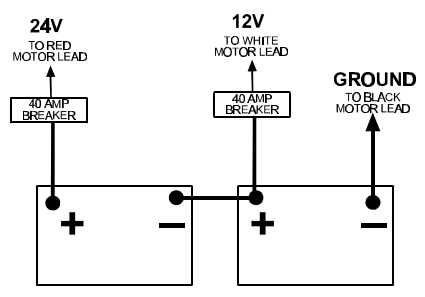
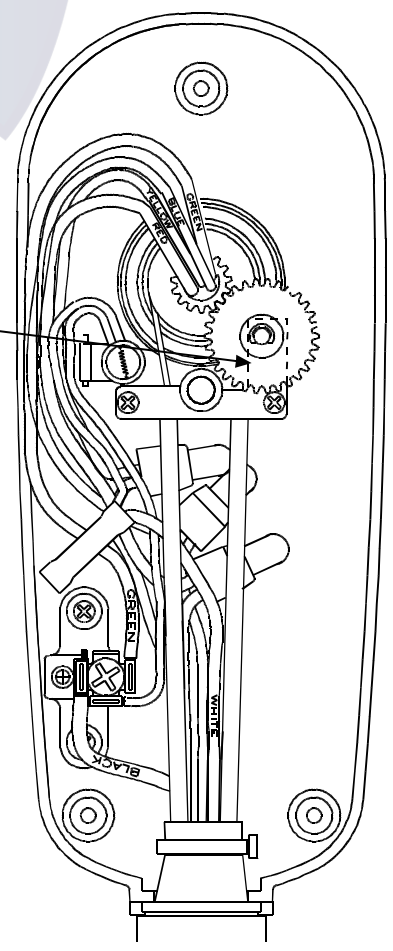

(BLACK) TOUR EDITION STEP SPEED PEDAL ASSY

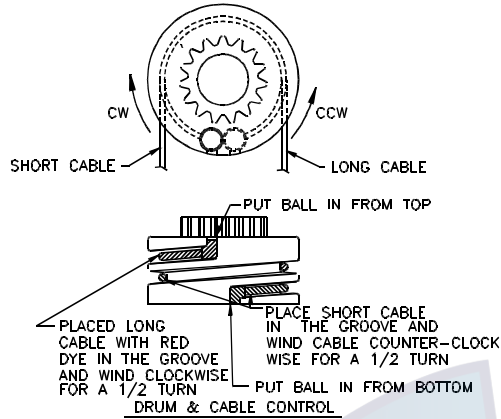

ITEM #	DESCRIPTION	PART #
1	SWITCH BOOT	FP177-01
2	TOGGLE SWITCH	PM3153-01
3	SCREW #6X32X1.12	PM135-01
4	6-32 NUT SS	SP098-02
5	MICRO SWITCH	AP151-01
6	FOOT PEDAL	PM101-03
7	ROTARY KNOB	PM082-02
8	NUT PUSH ON	PM046-01
9	ROTARY SWITCH	HF150-01
10	BATTERY CABLE	PM328-03
11	STEERING CABLE SHORT FOR 60"	PM027-01
12	STEERING CABLE LONG FOR 60"	PM027-02
	STEERING CABLE SHORT FOR 72"	PM027-03
	STEERING CABLE LONG FOR 72"	PM027-04
13	DECAL	PM057-04
14	BASE, PEDAL	PM003-01
15	COVER, SWITCH	PM026-01
16	MICRO SWITCH BOOT	KP157-01
17	FOOT PEDAL	PM101-03
18	PAD, FOOT PLATE	PM054-01
19	SCREW	FM133-04
20	PULLEY	PM121-01
21	PIVOT PULLEY	PM122-01

